

Conbility GmbH

Advanced Machine Systems
for Composite Production

Conbility – Profile

- **Founded 2015 in Aachen**
- **Location since 2019: Technology Parc TPH, Herzogenrath**
- **Strong Background in:**
 - Production Technology and Material Science
 - Development of Special Purpose Machines
 - Laser Processing Technology
- **Portfolio:**
 - Tape/ Fiber Placement Machines for Composite Production
 - Software for Cost and Eco Assessment
 - Technology Evaluation
 - Digital Transformation





Conbility – Premium Partner of the AZL-Network

Process Chains for Hybrid Composite Materials

Plastic Material- and Processing Technology

Production Technologies

Machine Tools and Production Metrology

Laser Technology

Automotive Science and Engineering

Fiber- and Textile Technology

Welding and Bonding Technology

Structural Mechanics and Lightweight Design



Conbility – Fields of Activity

Digital Transformation

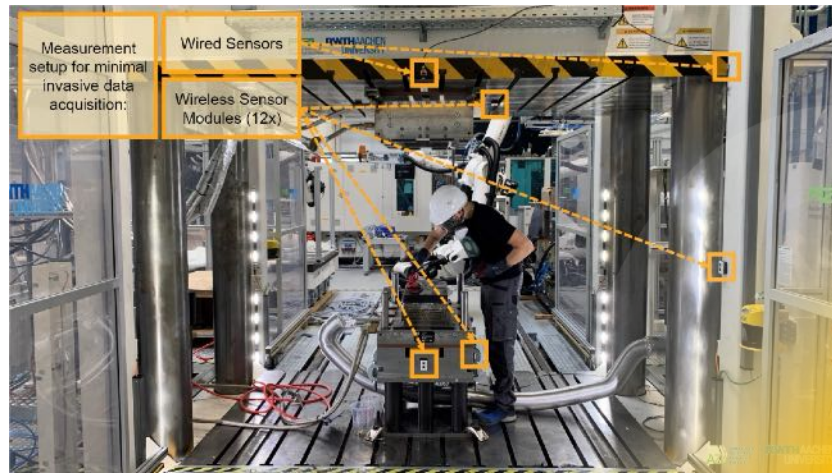

Tape Placement Machines

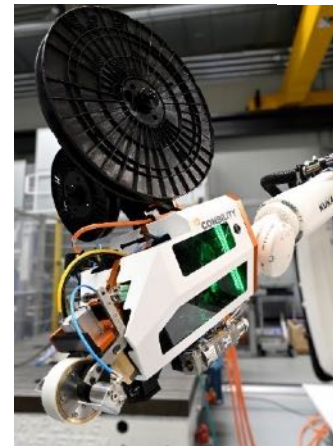

3D Tape Placement Applicator



2D Tape Placement Machine at Conbility

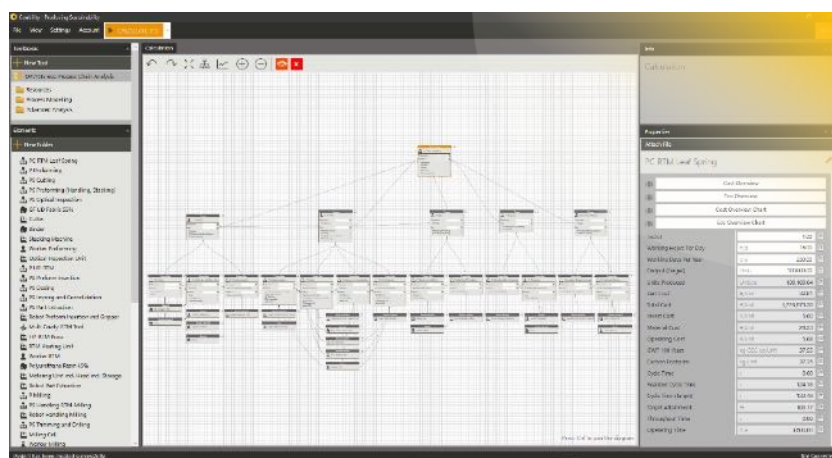

Software for cost and eco assessment

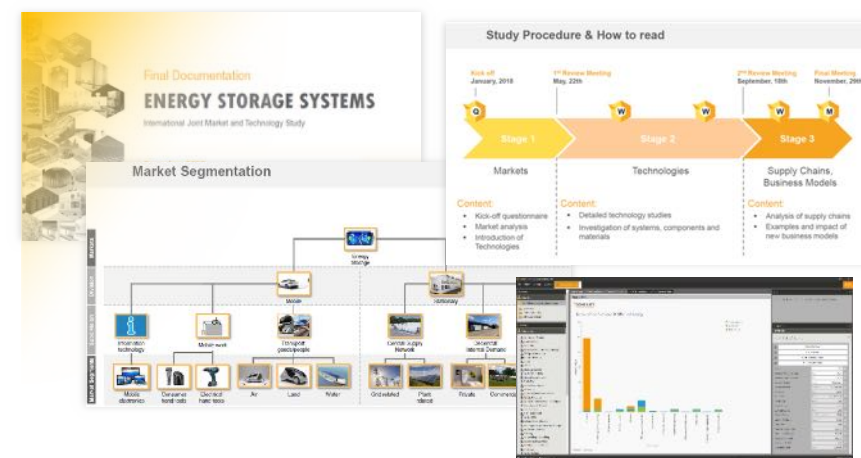

Technology Evaluation

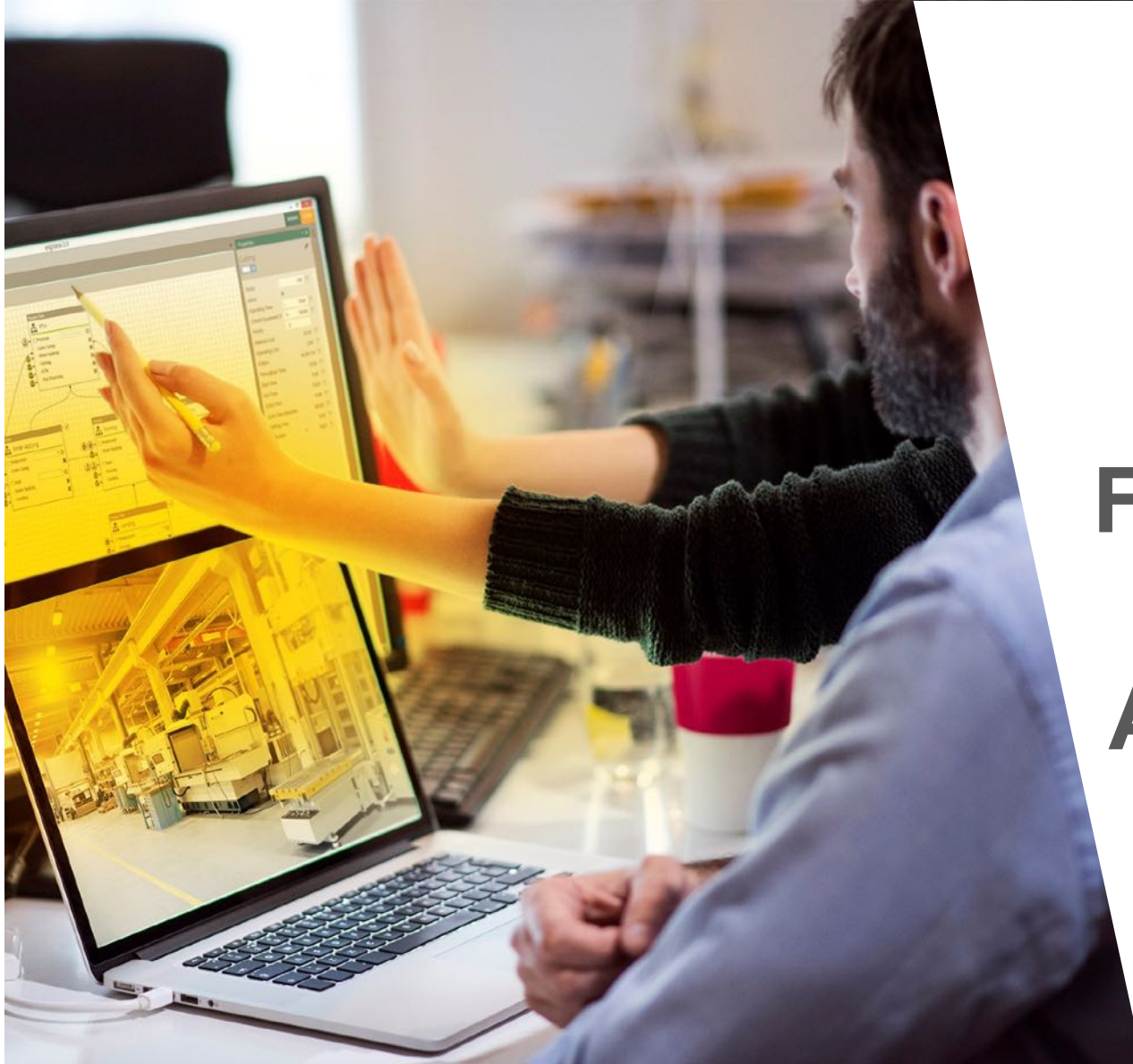

Software for Costing and CO₂ Footprint Analysis, Advisory Services

OPLYSIS® - Calculate Product Costs and Production Capacities

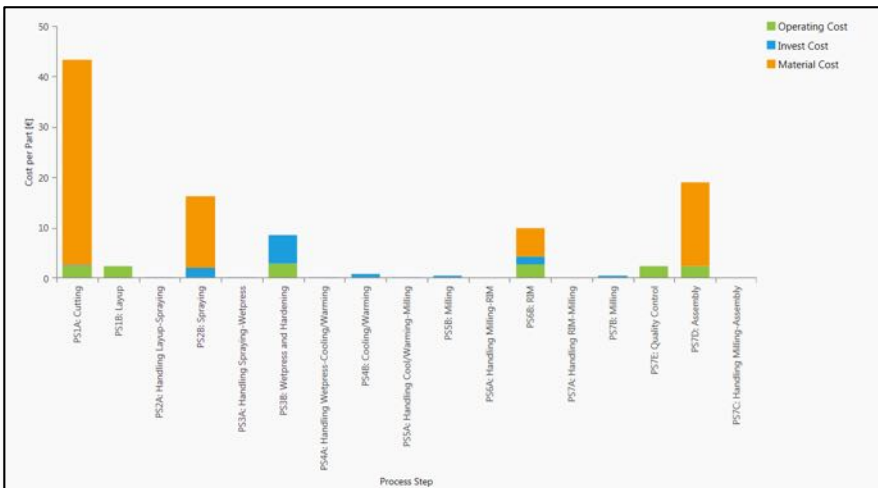
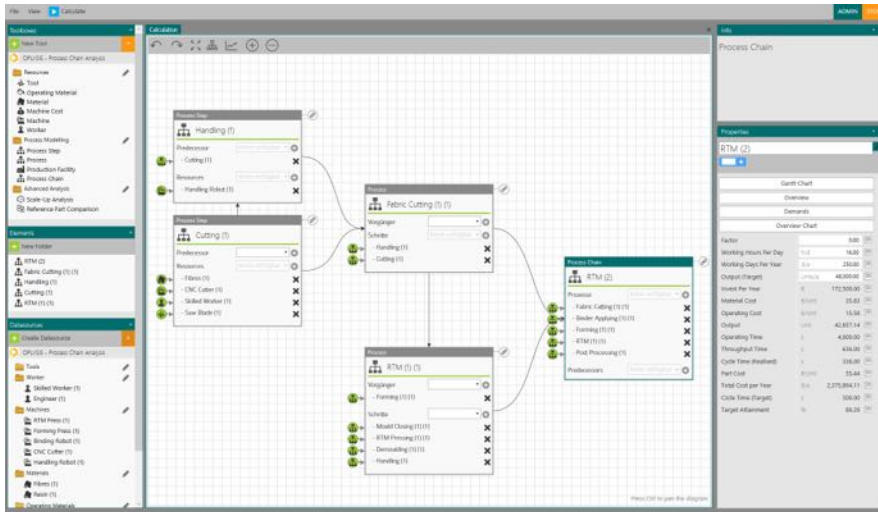

- **Costing Software** for calculating product costs and capacities of serial production scenarios
- **Drag&Drop Workspace** for easy and transparent modelling of production sequences
- **Branch- and Technology Independent** by using basic elements of Activity Based Costing methodology
- **Expressive** by providing cost structures and cycle times for every process stage
- **Fast** by adding and linking calculation elements by drag&drop
- **Easy-to-use** by guided input for the required information
- **Reliable** by using standard calculation routines and visual representations of interdependencies
- **Inspiring** by facilitating real-time modification and substitution of process sequences
- **Affordable** by flexible subscription model on monthly basis

Transparent process flow on different levels of detail

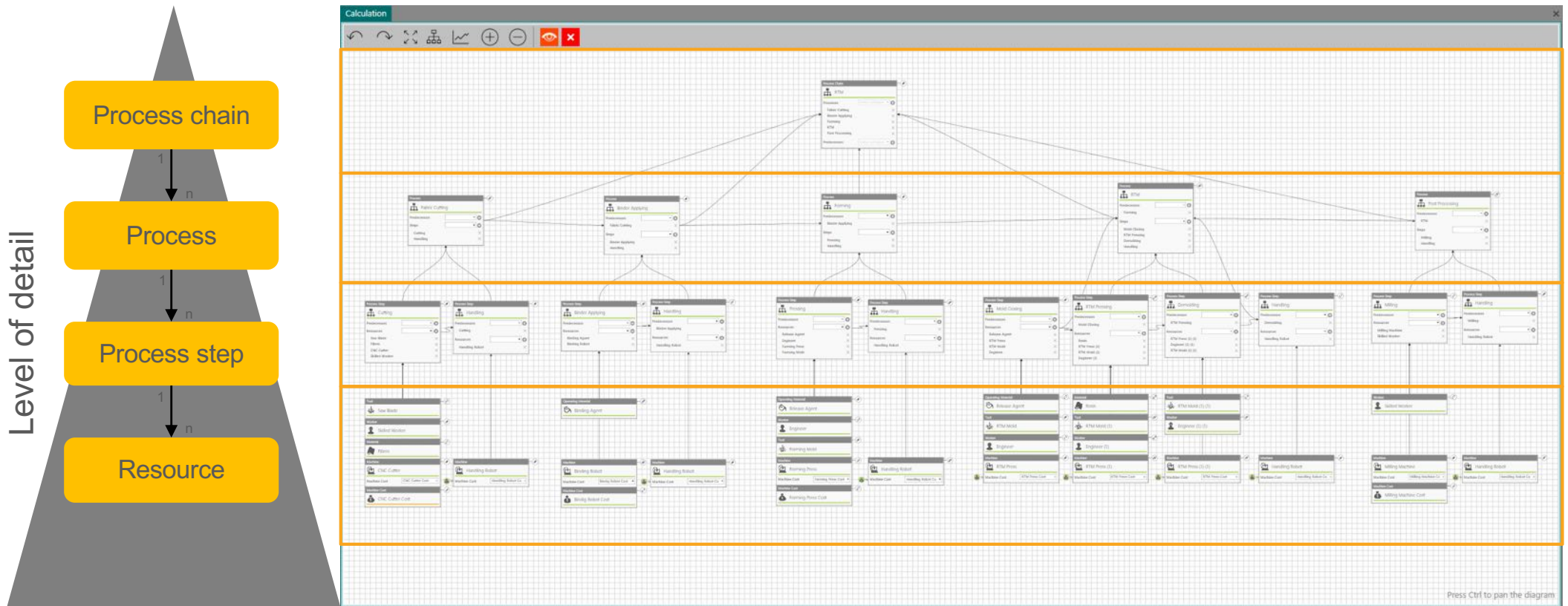

- ➔ Calculation of material, operating and invest cost on every level of detail
- ➔ Calculation of cycle and throughput time and output per year in consideration of i.e. scrap and resource availability

Transparent process flow on different levels of detail

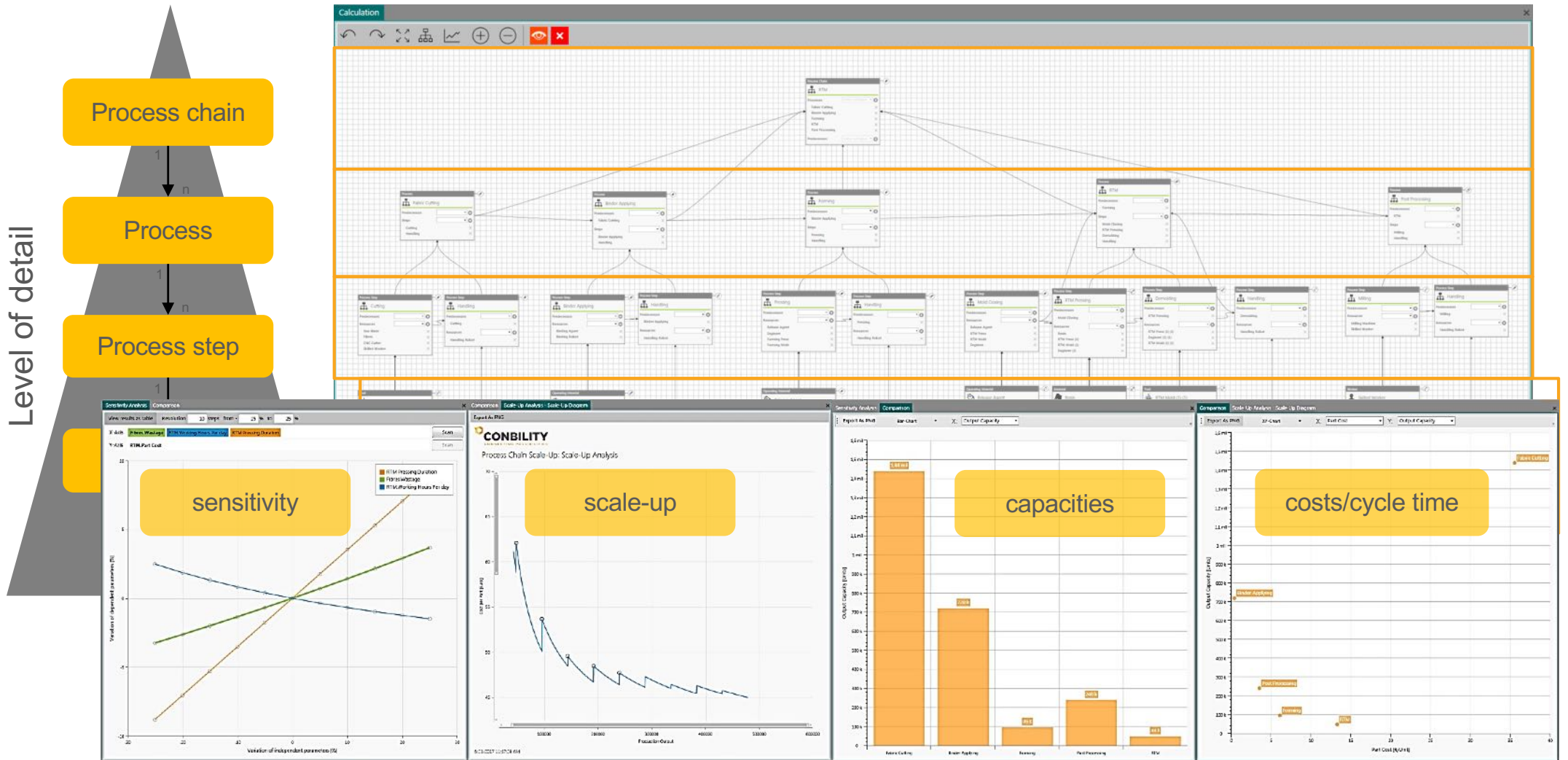

Our Products and Services



OPLYSIS® - Cost assessment along the value chain

Use of OPLYSIS in early stages before detailed production planning with PPS systems:

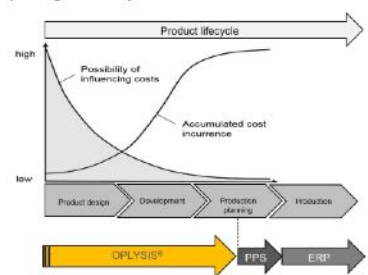

OPLYSIS enables early

- Assessment of invest and production cost
- Identification of cost drivers and bottlenecks
- Effects analysis of different production scenarios or alternative resources (materials, machines, activities, etc.)

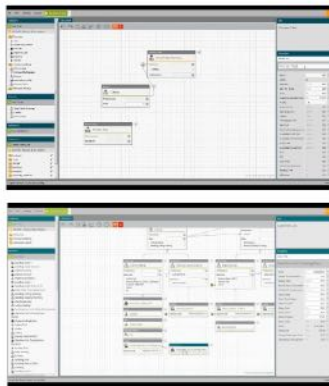

<https://www.youtube.com/channel/UC8oaSooG-ydZRU5W5NBQ>



Transparent process flow on different levels of detail

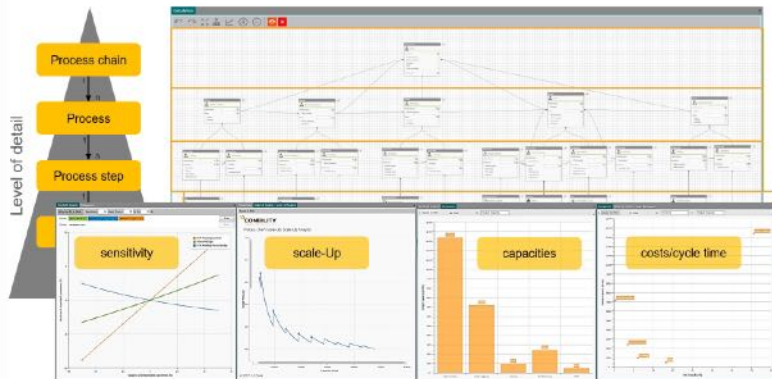

■ Product: Process Costing Software „OPLYSIS“

- Intuitive Drag&Drop Workspace
- Advanced Analyses (Sensitivities, Scale-up, Capacities)
- Assessment of Invest and Production cost
- Identification of Cost Drivers and Bottlenecks
- Effective Analysis of different Production Scenarios

■ Advisory: Modelling and Analysis with our Team

- Modelling of your existing Production or of different Production Scenarios
- Support in Production Planning
- Identification of Cost Drivers and Bottlenecks before Start of Production
- Technology Consulting

Production Cost and Carbon Footprint Assessment using OPLYSIS-eco

Process chain model as well as part cost and carbon footprint overview chart in OPLYSIS-eco

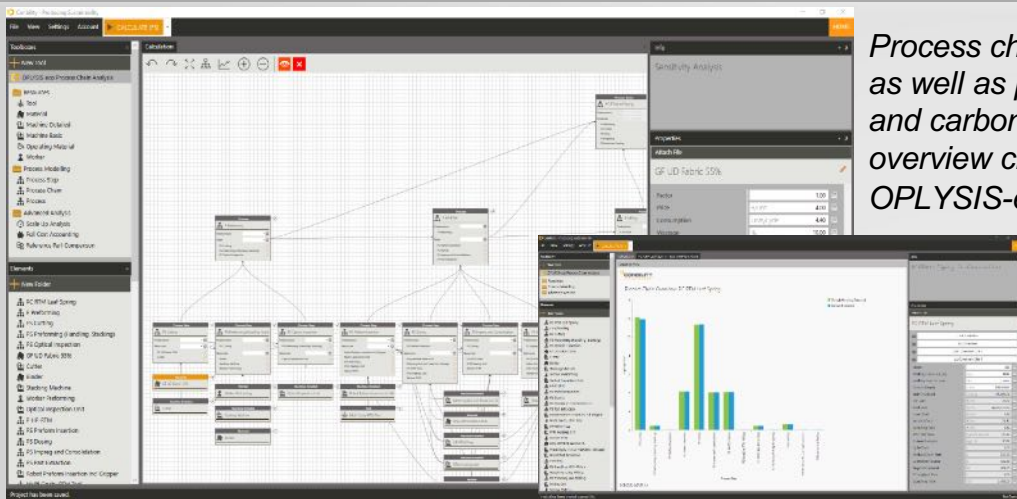

exemplary clients

- Integrated software for **simultaneous calculation carbon footprint, product cost and production capacities** of production scenarios
- **Drag&drop workspace** for easy, intuitive and transparent modelling of production scenarios
- **Branch- and technology independent** by using basic process chain elements suitable for any production scenario
- **Efficient analysis** of key performance drivers with **sensitivity analysis** and **scale-up analysis**
- **Inspiring** by facilitating real-time modification and substitution of process sequences

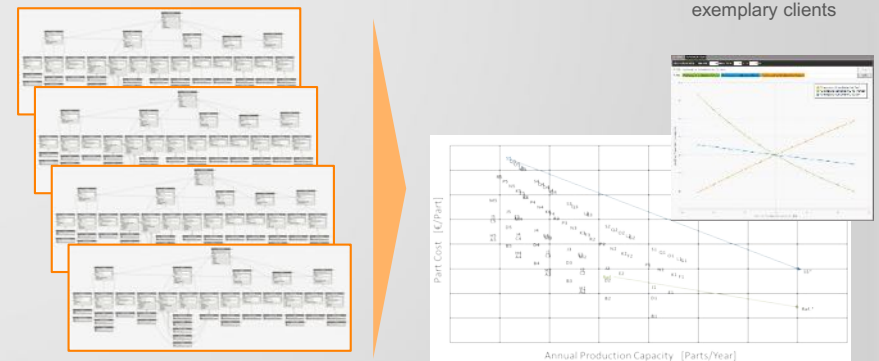

Easily derive multiple production scenarios by parameter variations and sensitivity analysis

What we offer:

- OPLYSIS-eco software license
- Benchmarking of Material and Process Technologies as an Individual Service

**Tape Placement
Systems**

**Double Belt Press
Systems**



Laser-assisted Tape Placement Motivation

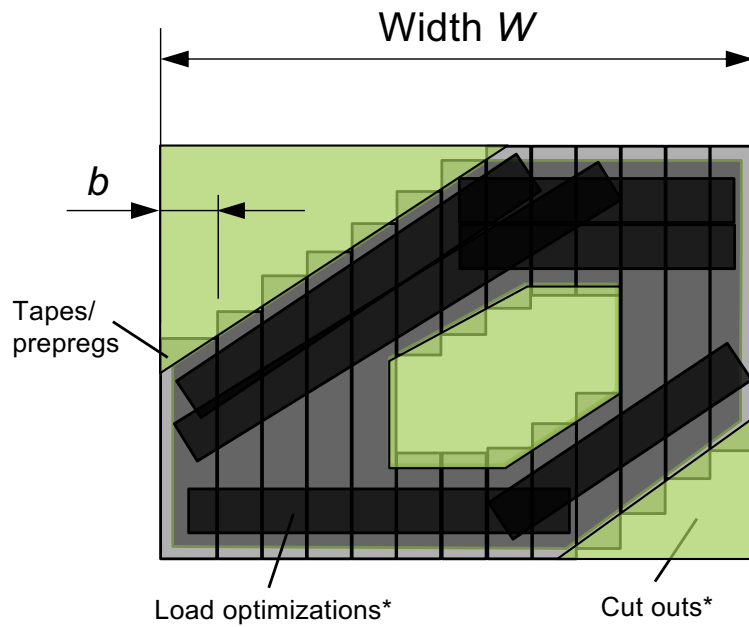

Tailored composite blank

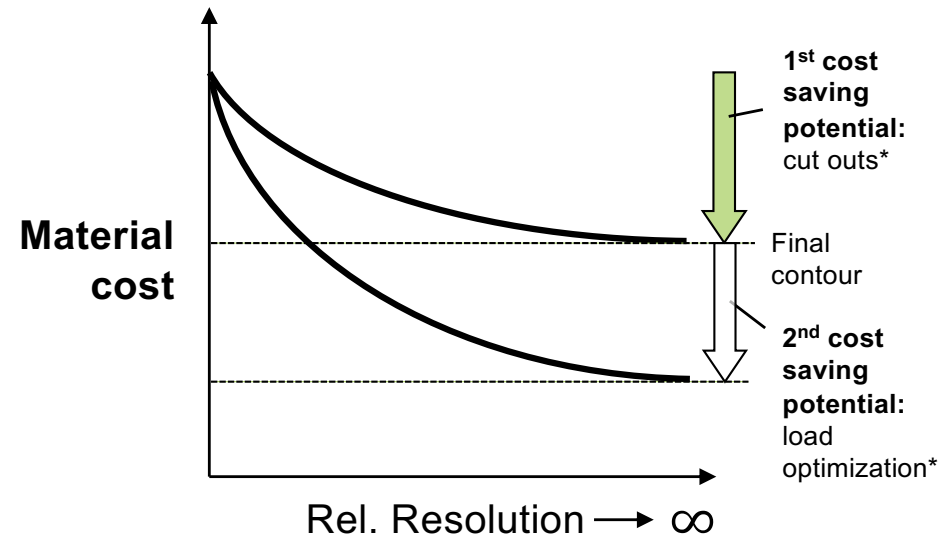

$$Rel. Resolution = \frac{W}{b}$$

* depends on the product design and mechanical requirements

Laser-assisted Tape Placement with in-situ Consolidation Process Principle and Advantages

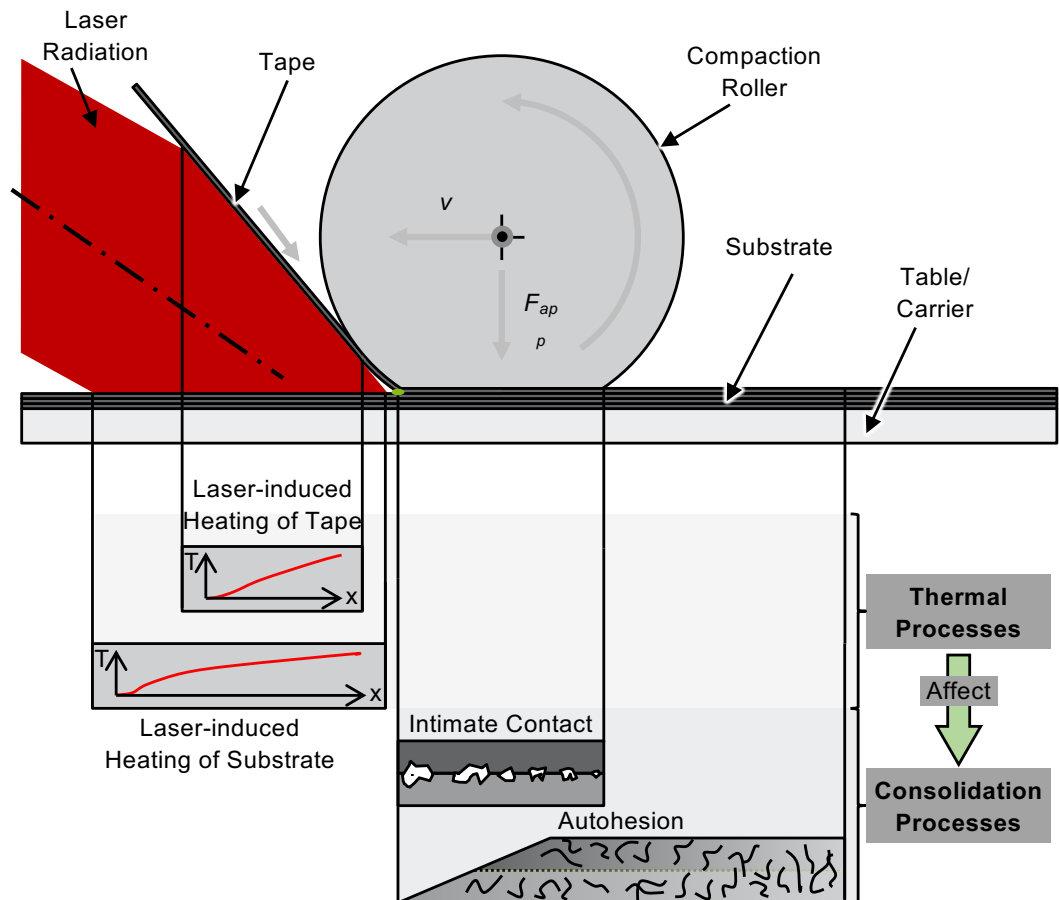

Advantages

- **Energy-efficient heating of process zone due to usage of laser radiation**
- **Precisely and fast controllable laser-induced heating**
 - Closed-loop control of laser power
 - Avoidance of over-heating
- **No post-consolidation processes**
 - Energy efficient and resource efficient
 - Cost efficient (process and investment costs)
- **High flexibility**
 - Thickness variations within a laminate
 - Usage of different tape materials within a laminate
 - Production of tailored 2D composite sheets
 - Final local reinforcements of parts or organic sheets
- **Advantages for subsequent thermoforming**
 - Better stability for handling operations
 - Strong laminate fixation during injection molding
 - Faster and more homogeneous heating before thermoforming due to complete contact of the tape surfaces

Exemplary Addressed Product Categories

Load- and cost optimized
multi-material combinations

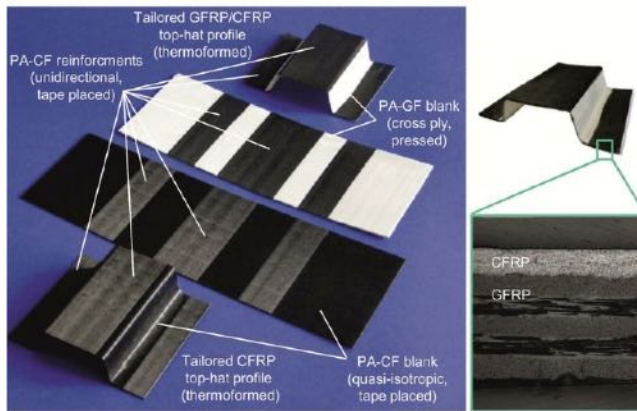

Picture: Fraunhofer IPT,
Aachen

Tailored Composite Blanks



Picture: Aachen Center for
integrative Lightweight
Production (AZL)

Composite vessels

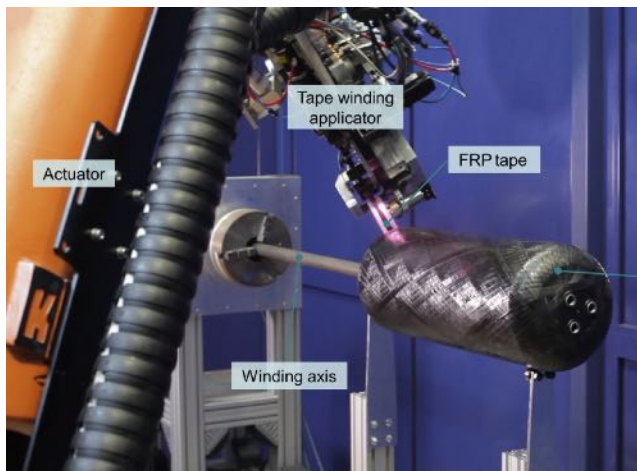

Picture: Fraunhofer IPT,
Aachen

Composite pipes

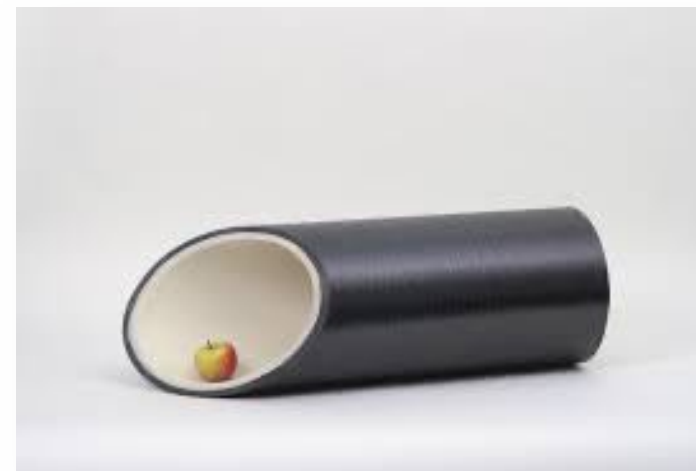

Picture: Fraunhofer IPT,
Aachen

Our Standard Tape Placement and Winding Systems

- 2D Tape Placement Machine

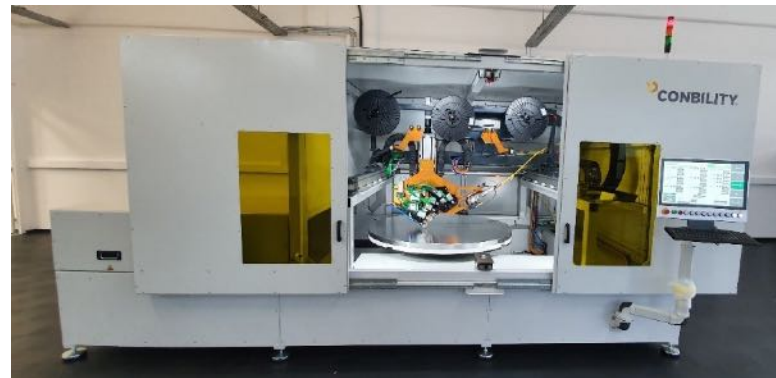

- 3D Tape Placement Head „Multi-Material-Head“

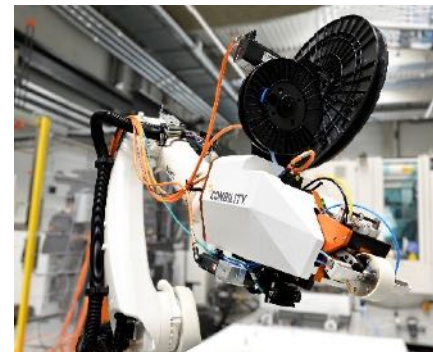
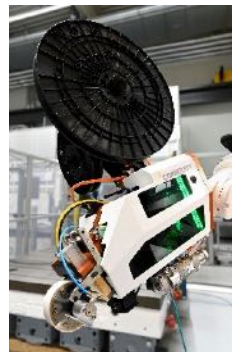

Our Standard Tape Placement and Winding Systems

- **2D Tape Placement Machine**

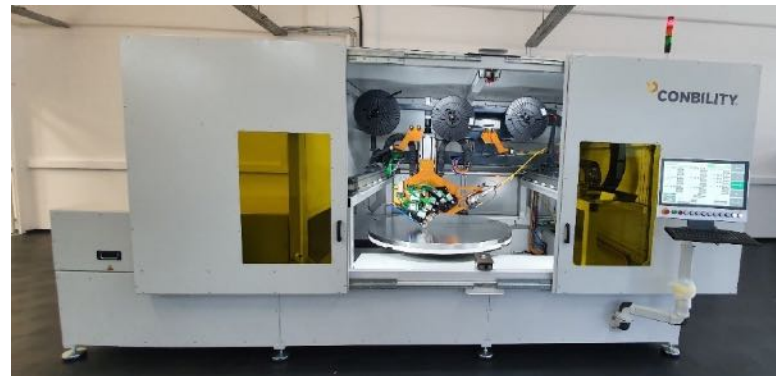

- **3D Tape Placement Head „Multi-Material-Head“**

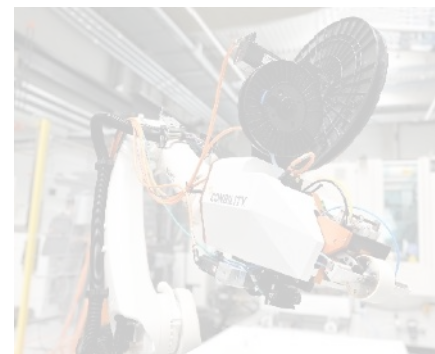

2D Tape Placement Machine

Laser-assisted Tape Placement with in-situ Consolidation

Laser-safe and Key-ready Maschine for laser-assisted Tape Placement with in-situ Consolidation

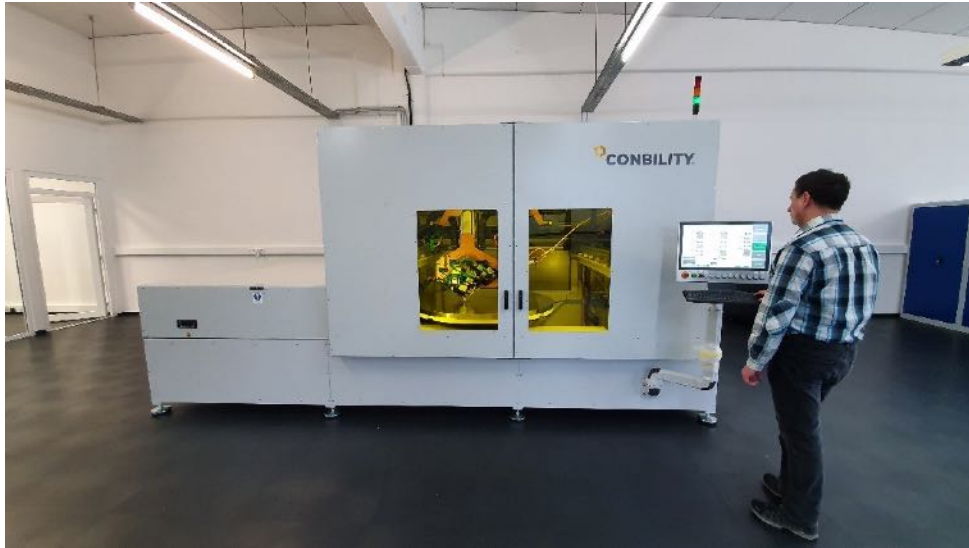

PrePro 2D for laser-assisted tape placement:

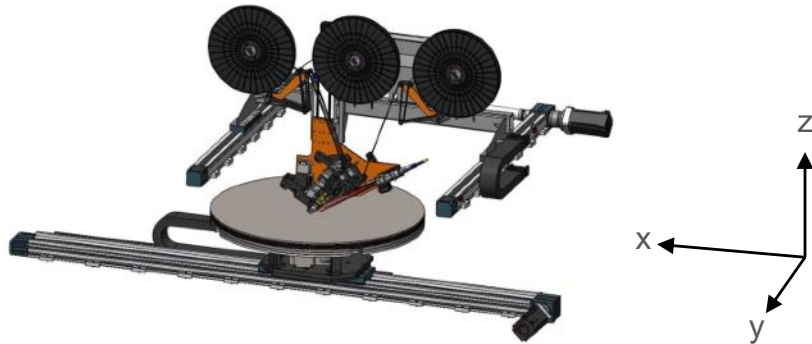

Video:



YouTube Video:



https://youtu.be/Q_pKDH006xo

System Properties

- Table size: up to \varnothing 2 m
- Multiple tapes possible
- Process speed: up to 1 m/s

Machine Characteristics

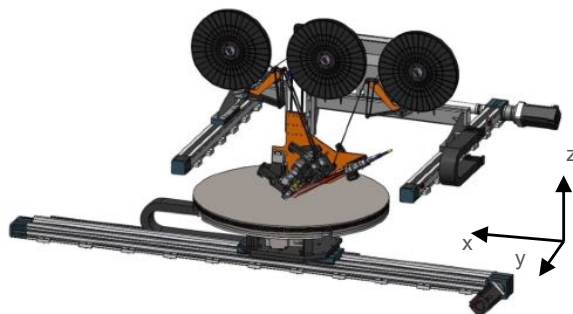

- **Plug&Produce Production Machine** for manufacturing tailored composite blanks by automated thermoplastic tape laying
- **Small footprint** of 5 x 2.5 x 2.5 m³
- **Flexible arrange- and reconfigurable on the shop-floor** by low weight of 3.2 t, moveable by forklift
- **Integrable into fully automated production lines** by automated unloading mechanism
- **Direct further processing of laminates in thermoforming** by using in-situ consolidation (no additional costly, energy-consuming and space-demanding consolidation step needed)
- **High cost- and material efficiency** by independent cut and add on-the-fly for each tape
- **High productivity** by consolidation of tapes with up to 1 m/s and simultaneous placement of three tapes in parallel
- **Highest standard for the laminate quality** by using aerospace proven laser heating
- **Prevention of over-heating** by temperature-control in the process zone
- **Flexible adaptable of tape material** by exchangeable modules to cover tape widths from 6 to 25 mm, thickness up to 0.3 mm
- **Full control and documentation of all relevant process parameters** by user-friendly HMI and machine control

Main Specifications

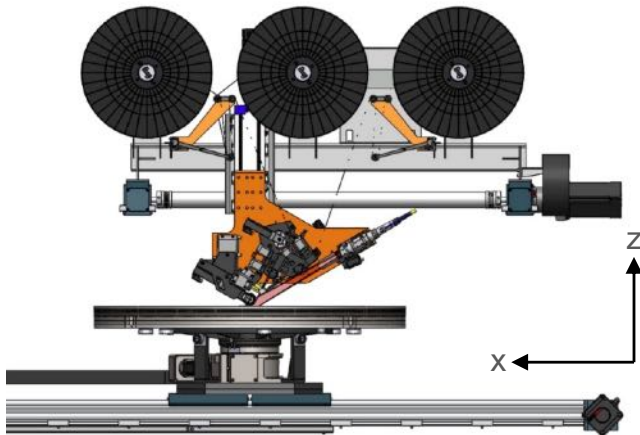

■ General Specifications:

- Machine dimensions: 5 m x 2,5 m, weight: 3,7 tons, (approx.)
- Laser safety class 1 (laser safe stand alone machine system)
- Process: laser-assisted tape placement with in-situ consolidation
- Free choice of tape (fiber) directions
- Variation of different thicknesses within a laminate
- No post-processing for consolidation

■ 3 x Spool Applicator:

- Tape width: standard 25 mm (3x)
- Tape thickness: <0,3 mm, minimum length <95 mm (tape 1+3), <112 mm (tape 2)
- Translational Z-axis for applicator movement (vertical direction / blank thickness): 100 mm
- Translational Y-axis for applicator movement: TCP on complete table surface
- Automatic pneumatic cutting unit for „cut-and-add-on-the-fly“
- Exchangeable cooled compaction roller units: 1x rigid surface and 1x elastomer surface
- Adjustable consolidation force up to approx. 500 N

■ Rotary Table with integrated Heating Functionality:

- Table diameter: 1,500 mm, alternative 2,000 mm
- Max. heating temperature table: 200 °C
- Rotary table (+/- 90°) and translational X-axis for table movement
- Max. speed in X-direction: 1m/s (typical process speed for PA-tape: 850 mm/s with laser)

■ Laser System:

- 4 kW high power diode laser incl. cooling, optical fiber and processing optics

■ Control System:

- Beckhoff industrial control system including HMI based on TwinCat 3.1 and G-code
- Controlable process parameters: speed, laser power (temperature), compaction pressure
- Recording of process parameters, IR-camera for monitoring of process zone and temp. control

Configurable and Scalable Machine Setup

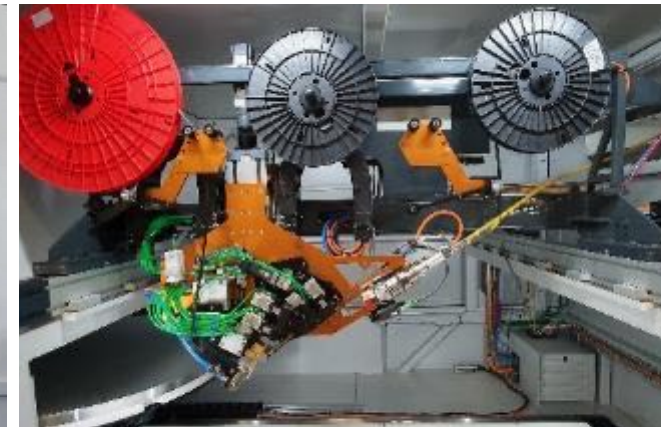
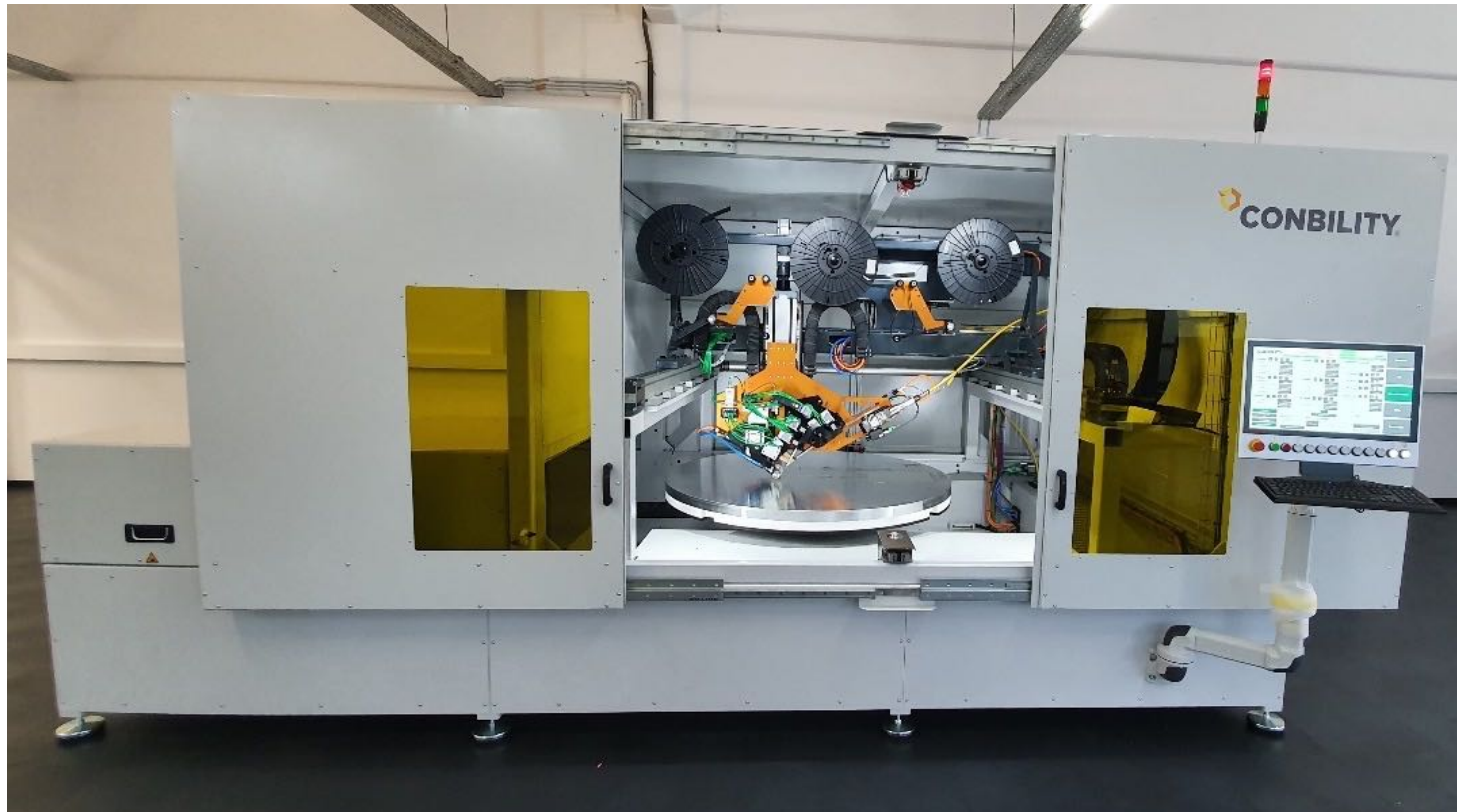

System Properties

- Heating table: Ø 1,5 m (scalable up to 2m)
- 3-spool-applicator (scalable)
- Integrated 4 kW Laser system (scalable)
- Process speed: up to 1 m/s

Our Standard Tape Placement and Winding Systems

- 2D Tape Placement Machine

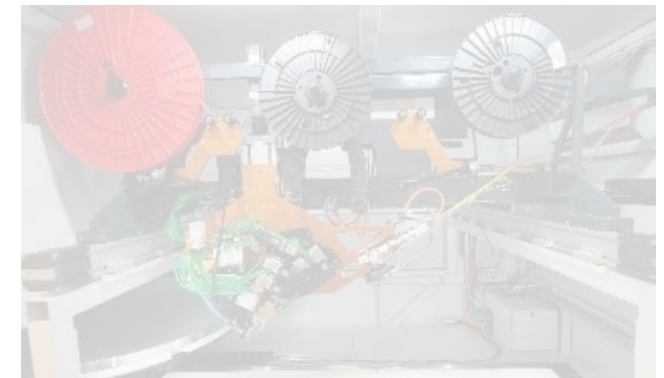
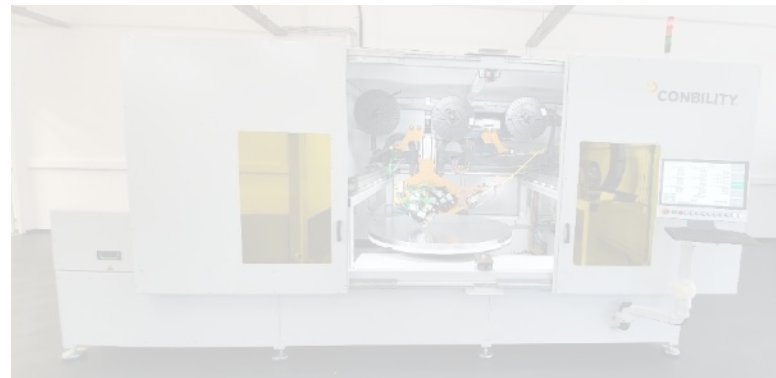

- 3D Tape Placement Head „Multi-Material-Head“

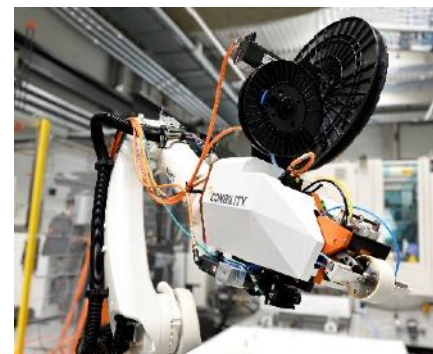
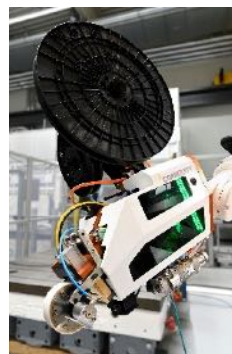

3D-Multi-Technology-Tape Placement Unit

Compact and configurable placement system for automated 3D layup of rovings, prepregs and towpregs

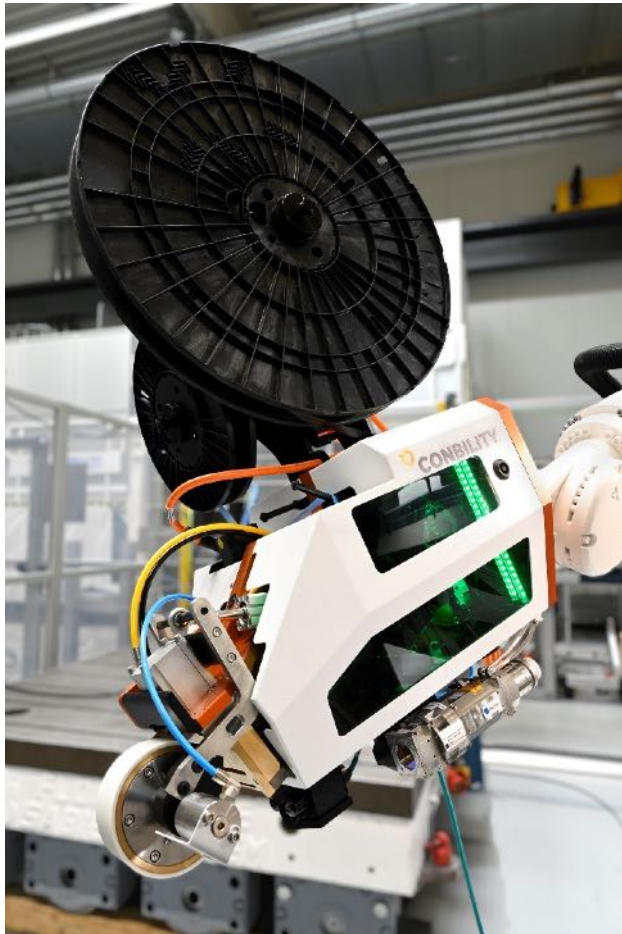

Properties of the system:

- One investment for the processing of 3 different materials:
 - Thermoplastic CFRP and GFRP Tapes
 - Thermoset CFRP and GFRP Prepregs
 - Dry Fiber Rovings
- Suitable for placement and winding operations
- Single tows/ tapes with width up to 50 mm
- Tape tension control
- Infrared heater to increase tack of resin
- Prepared for integration (plug-in) of a high-power diode laser system, e.g. 4 kW: mechanical interface for the optical systems, control system preparation
- BECKHOFF-based decentral control system communicating with robot control system, including process parameter close-loop-control and HMI
- Can be mounted to a standard robot and is compatible to standard robotic control systems, e.g. KUKA



Conbility's Tape Processing Applicator – Main Characteristics

- **Closed-loop control of**
 - laser power for defined temperatures in process zone (high-speed pyrometer for control, high-resolution thermal camera for quality and process monitoring),
 - tape tension,
 - Consolidation force pressure roller.
- **Modular and Reconfigurable**
 - **Scalable tape widths**, e.g. 6 mm, 12 mm, 25 mm up to 50 mm within the standard 50 mm tape processing applicator
 - **Additional upgrade of max. tape width up to 100 mm** for the tape processing applicator available
 - All parts (rollers, bearings, guidings, etc.) capable for **heavy-duty operation**, easily exchangeable for maintenance and **adaption for special purposes** (e.g. special fibre materials like ceramics)
 - Upgradeable for **dry-fiber placement and prepreg placement** with alternative resins as addition to thermoplastic tapes (**thermoset prepreg**, also with tension-controlled unwinding of backing paper)
 - **Reconfigurable** for e.g. multiple tapes, optimizations for vessel winding and special tasks like ring winding
 - **Flexible platform** for reliable and robust processing conditions

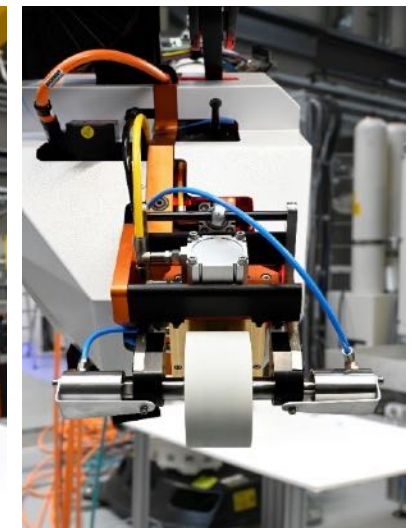
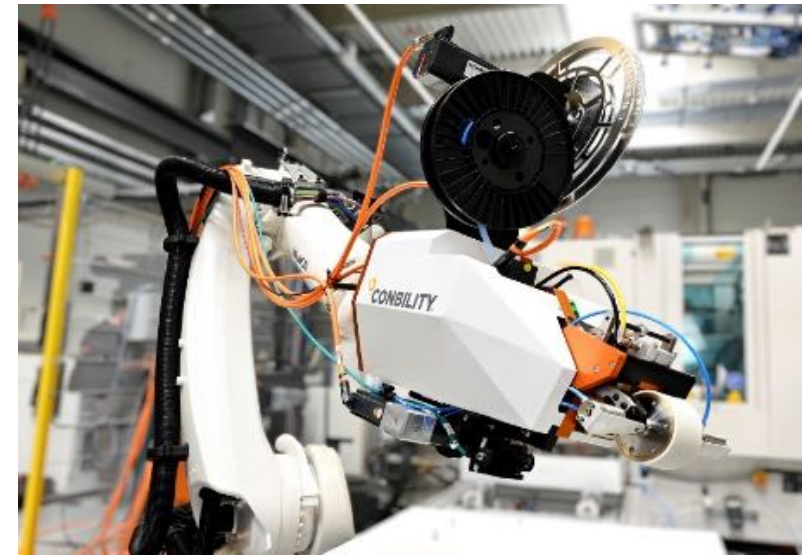

Conbility's Tape Processing Applicator – Additional Features

- **Adjustable Laser-inclination** (defines distribution of laser power incoming tape/substrate) via servo motor during process
- **Scalable in width** according to client's demand (e.g. 90° gear for spool drive, compact roller, compact robot interface, positioning of pyrometer/IR-camera)
- 78 kg weight
- **Beckhoff Industrial PC-based control**
- **Laserline high-power diode laser, 24/7 capable**
- **Fluid-cooled laser homogenization optic** with high working distance (low contamination potential) incl. easily exchangeable protection glass

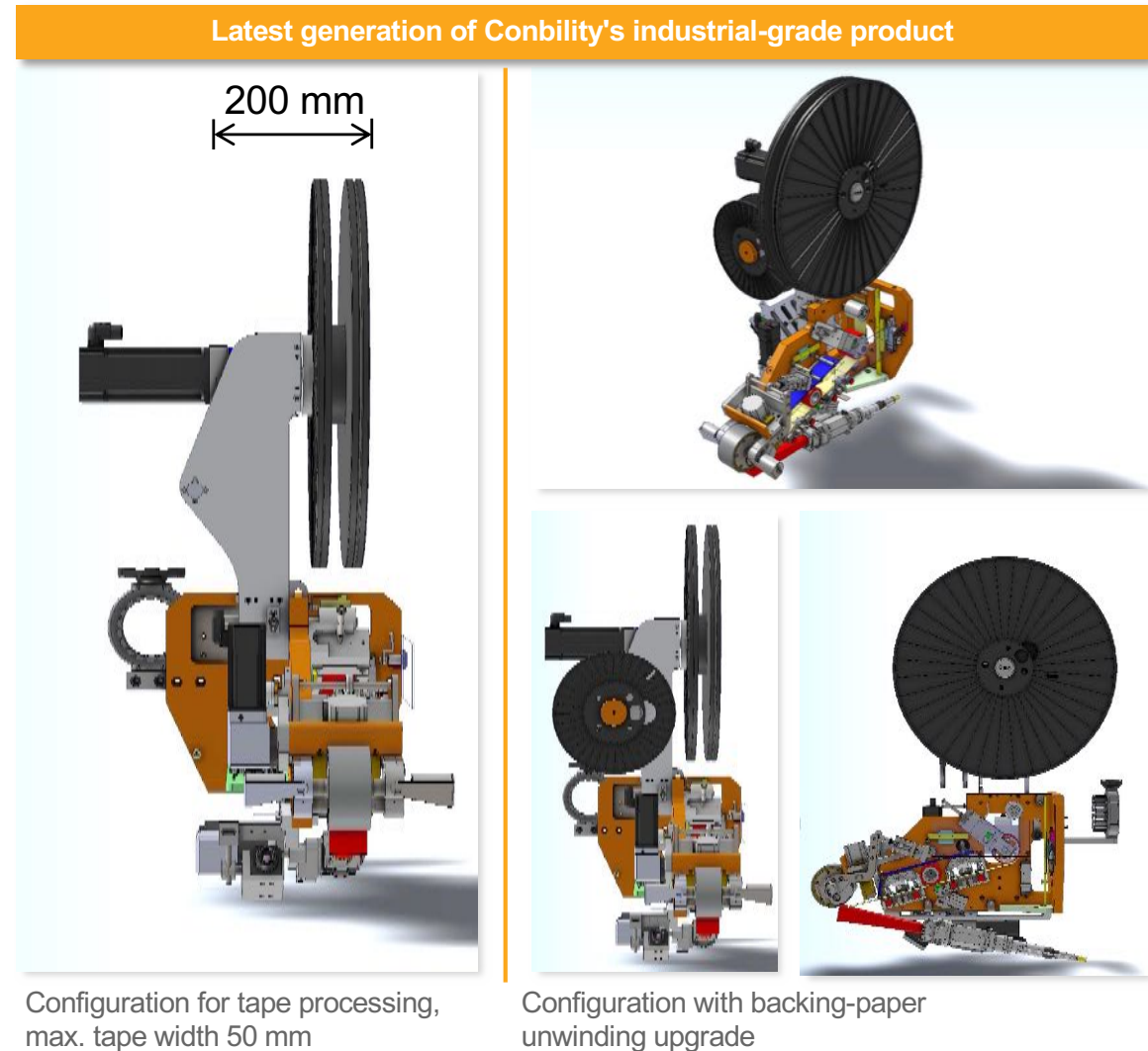

Conbility – Reference Tape Winding Cell

Laser-safe Winding Cell for thermoset towpreg winding and thermoplastic tape winding at Conbility's technical center in Herzogenrath, Germany



CAD-CAM

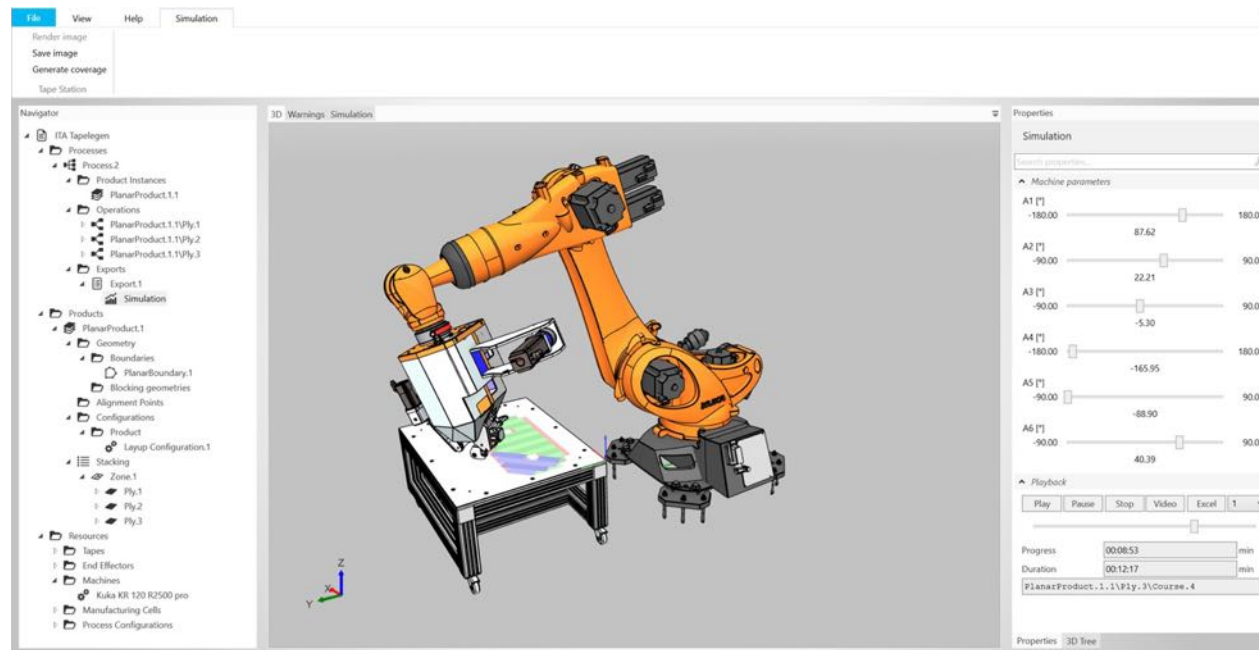

simulation of created programs

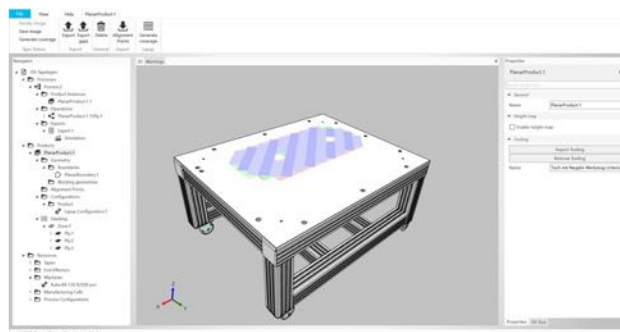

generating of layout

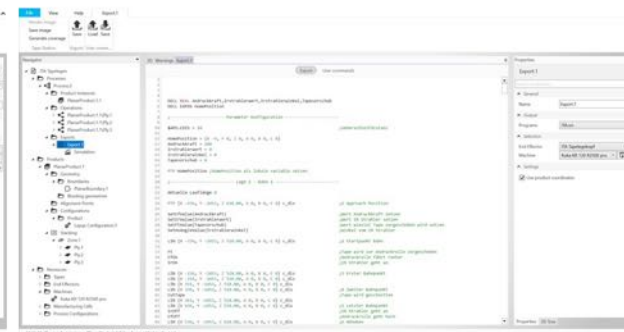

post-processing

Conbility – References Tape Processing Systems

- AIMEN Centro Aplicaciones Láser, O Porriño - Pontevedra, Spain



- University of Limerick - Castletroy, Ireland



- Bilsing Automation Tic. Ltd. Sti.- Bursa, Turkey



- Institute for Textile Technologies - Aachen, Germany



Exemplary integration @ AIMEN Technology Centre, Spain

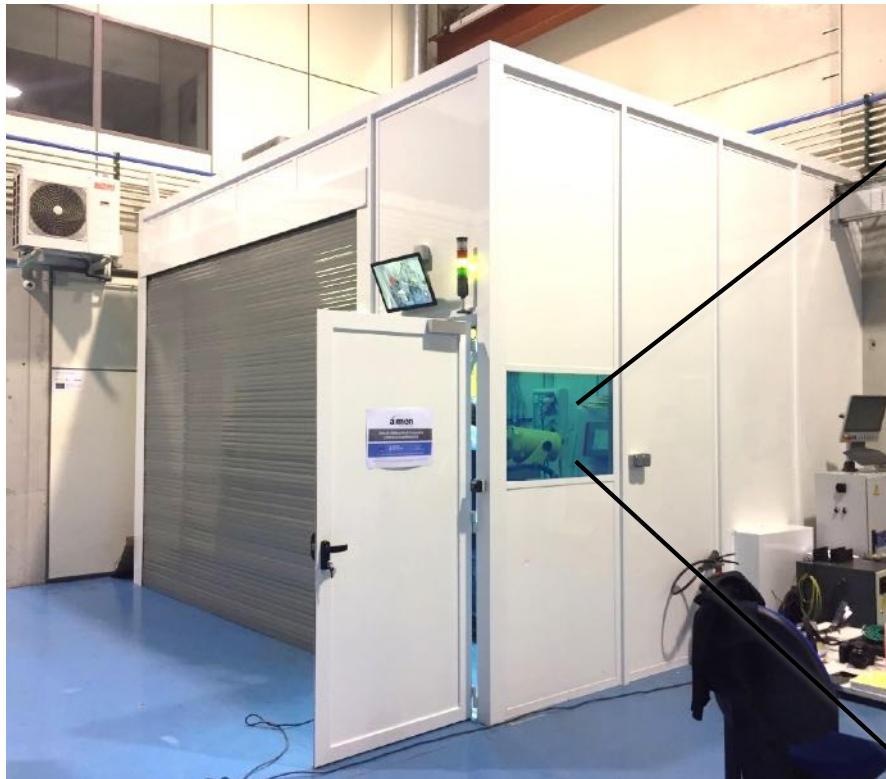

Laser safety cell

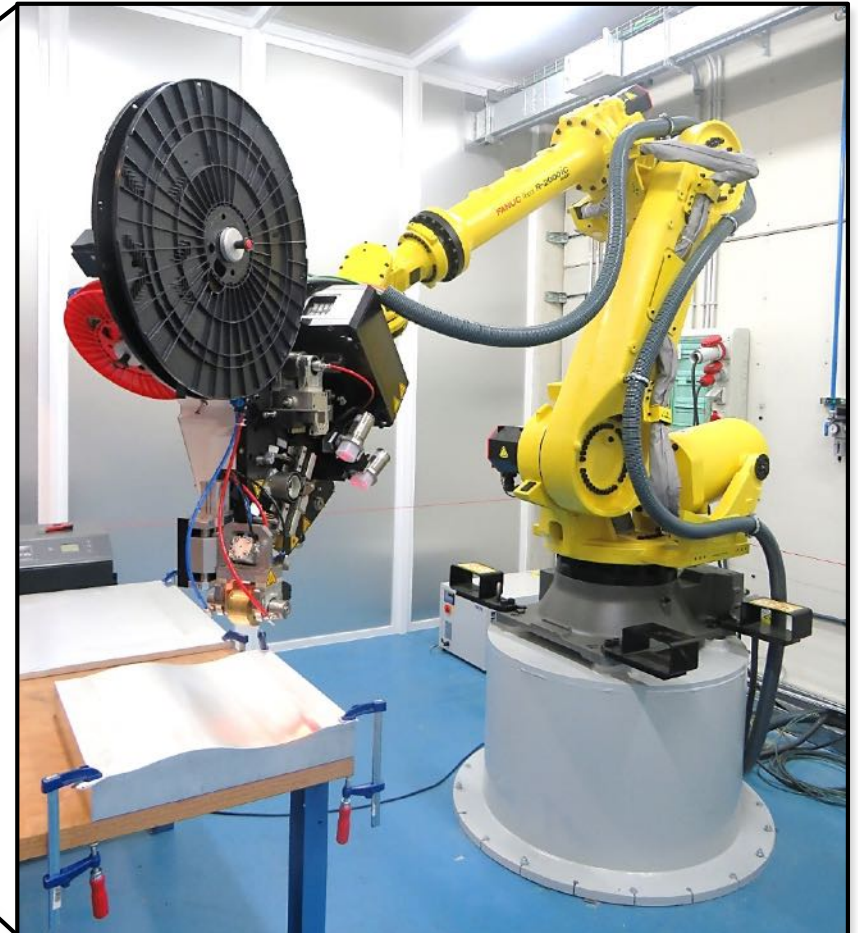

ATL on FANUC robot

Integration @ AIMEN Technology Centre, Spain

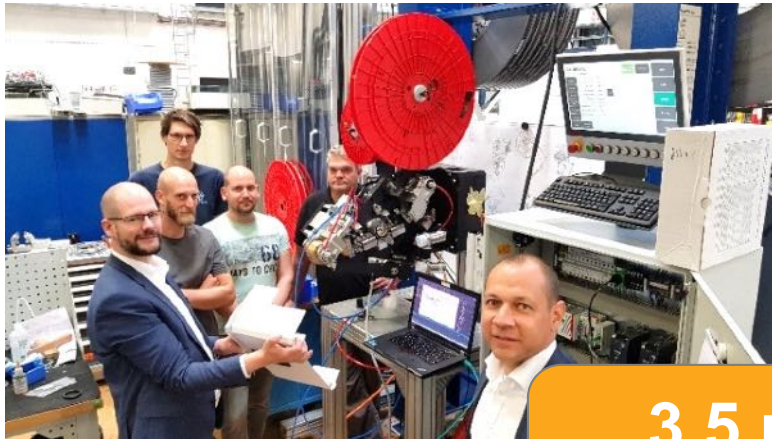

3.5 months from
PO to acceptance

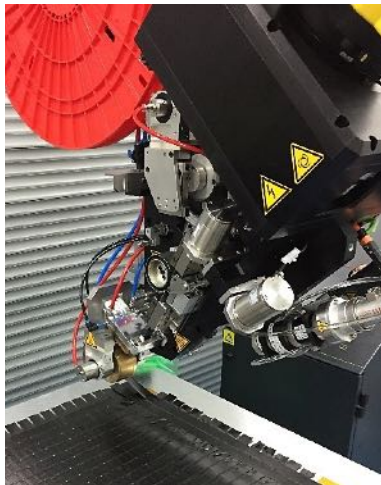

Integration @ Limerick University in Ireland

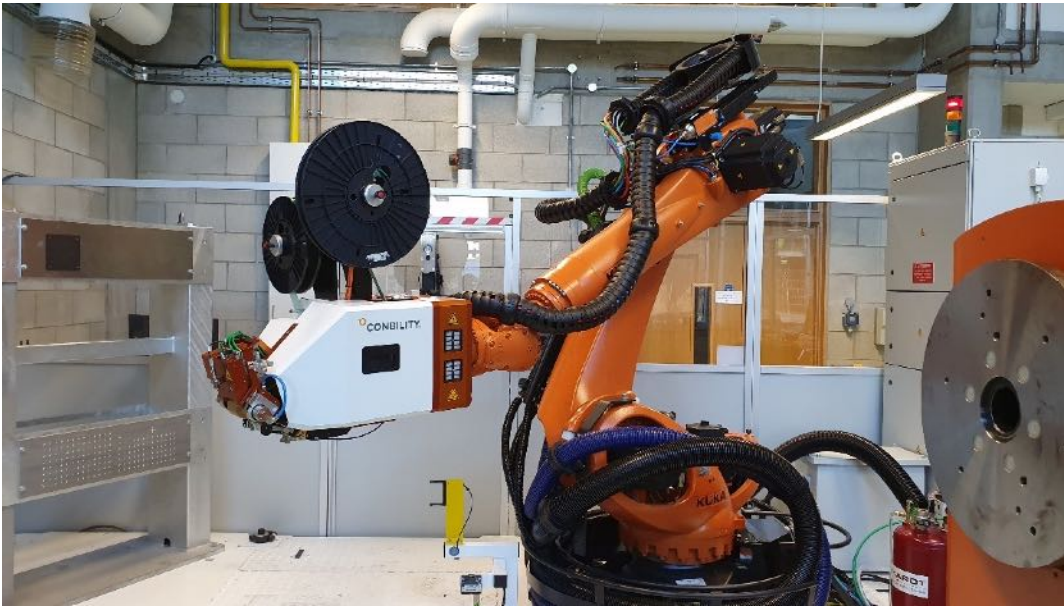

Our Products and Services (Production Systems)



Our Standard Tape Placement and Winding Systems

In cooperation with
Fraunhofer

2D Tape Placement Machine



3D Tape Placement Head „Multi-Material-Head“



■ Tape Placement Machine Systems

- 2D Tape Placement Machine
- 3D Tape Placement/ Winding Head („ATP-Head“)
- Key-ready Manufacturing Cells
(Customized - Including Robot, Laser Safety Cell, Winding Axis, etc.)



Our Service:

Job-order Manufacturing (Job-Shop): Tape Placement and Winding

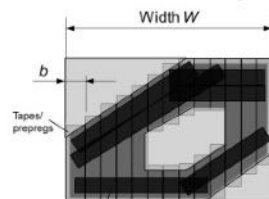

Load optimizations*

Tailored composite blank

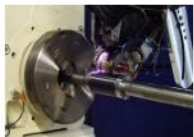

■ Job-order Manufacturing (Job-Shop)

- Manufacturing of Test Laminates (2D, 3D) by Tape Placement with in-situ Consolidation
- Manufacturing of Test- or Prototype-Parts by Tape Placement or Tape Winding (e.g. Tubes, Pipes)
- Local reinforcement of metal parts or thermoplastic parts (e.g. Injection Molded Parts or „Organo-Sheets“)

Inductive Double Belt Press



Inductive Double Belt Press System



Impregnation example:

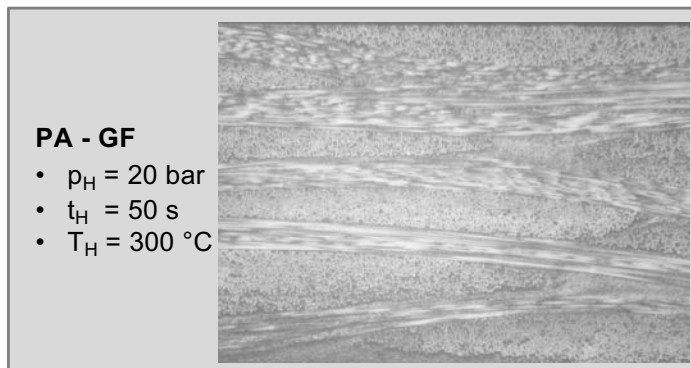

- Energy- and cost-efficient inductive heating system
- Consolidating and impregnating a wide variety of composite materials
- Highly flexible: all parameters adjustable within minutes (e.g. pressure, temperature, speed)
- Max. Temperature: 300 °C
- Max. Pressure: 24 bar
- Steel belt width: 350 mm (scalable)

Double Belt Press System

Start-up Video of the HMI



Start-up Video of the Machine



Impregnation Trials – PA6 and Glass Fiber Textile

Layup:



Material right out of the machine (no post-processing done)



Average temperature measurements

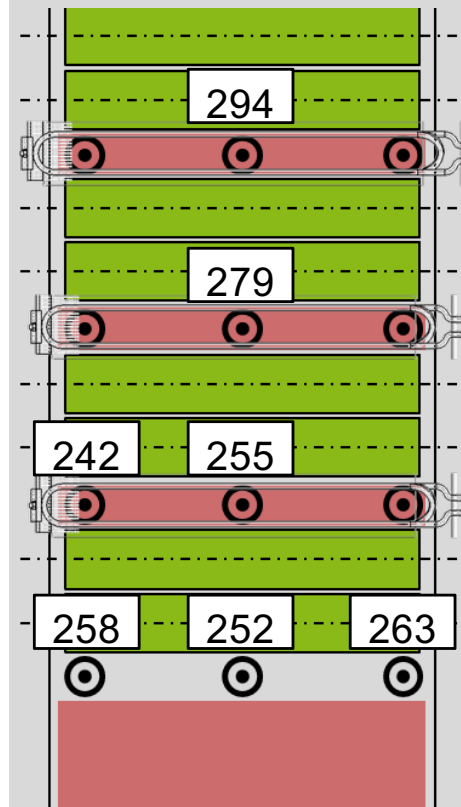

Comments:

- Processing speed: 500 mm/s
- Glossy and smooth surface without visible voids
- Minimal fiber washing
- Component flat and stiff

Microsection:

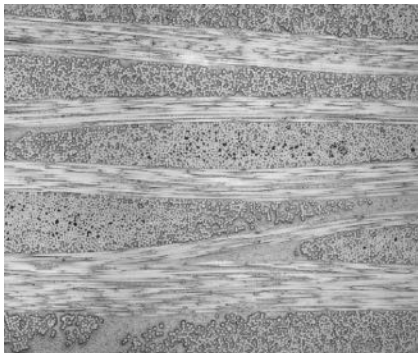

Pressure distribution during trials (pressure per cylinder [bar])

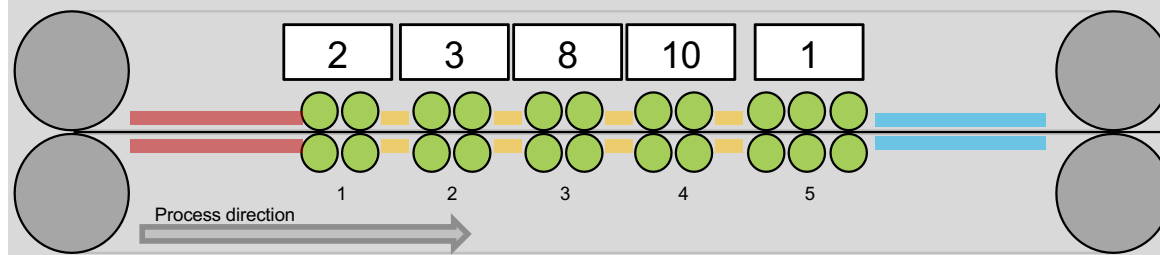

Consolidation Trials – 5 Layer PA12-CF Tape

Layup:

Material right out of the machine (no post-processing done)



PA 12 – CF Tape

Comments:

- Processing speed: 700 mm/s
- Glossy and smooth surface without visible voids
- Minimal fiber washing
- Component flat and stiff



Average temperature measurements [°C]

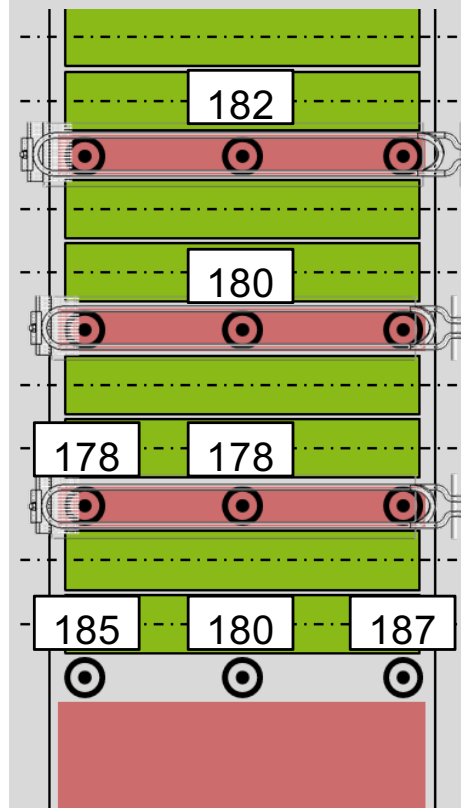

Microsection:

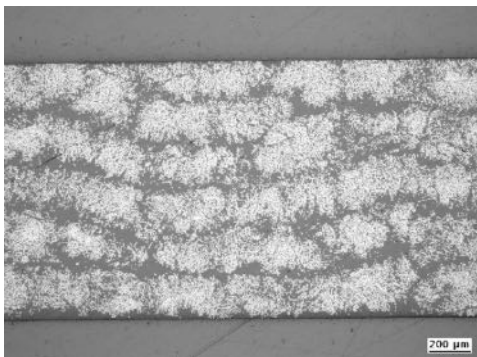

Pressure distribution during trials (pressure per cylinder [bar])

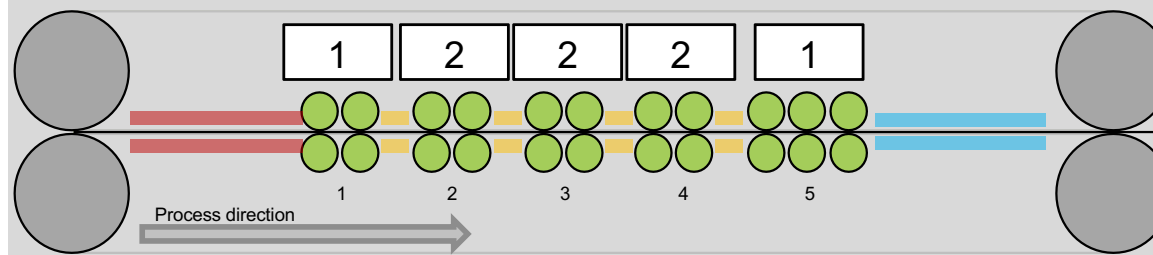

Consolidation trials - CF-PC tape

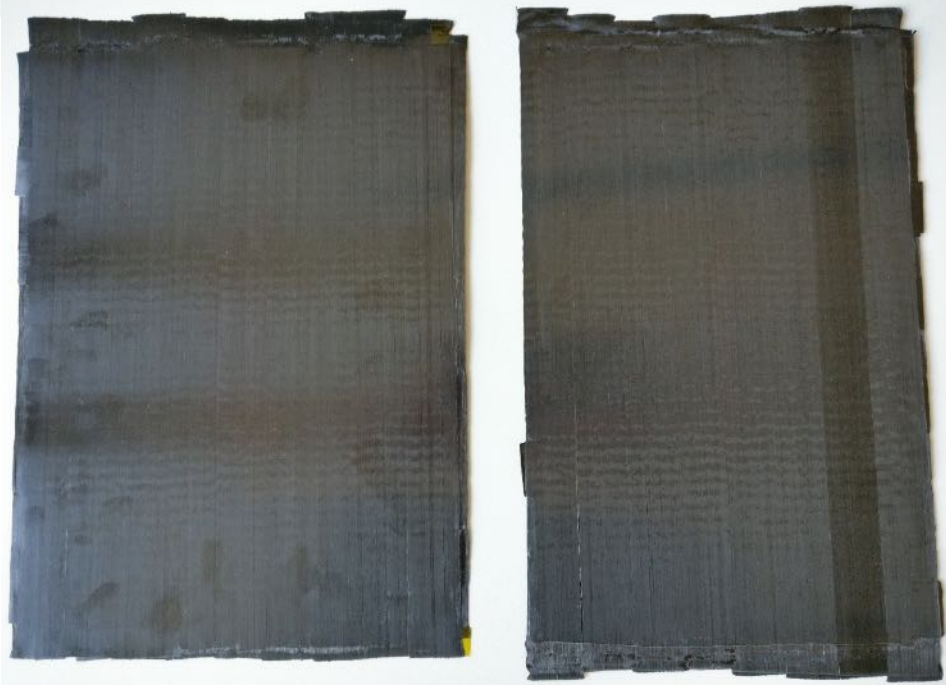

- Very good consolidation of layers
- Very smooth and glossy surface
- Local thickness variations of 3 tapes are no issue
- No issue with polymer sticking to belts

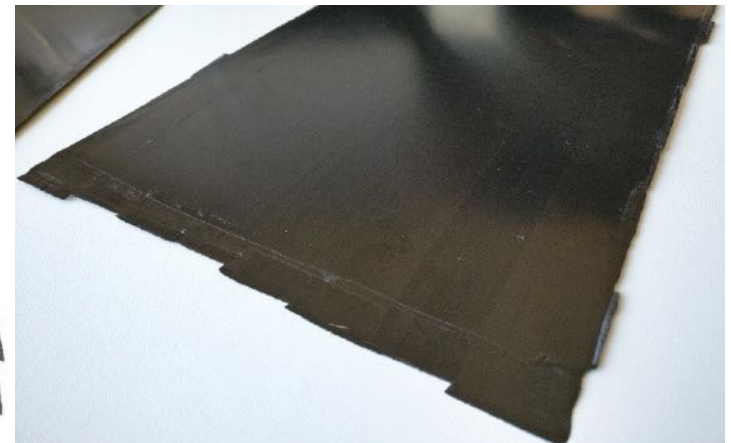
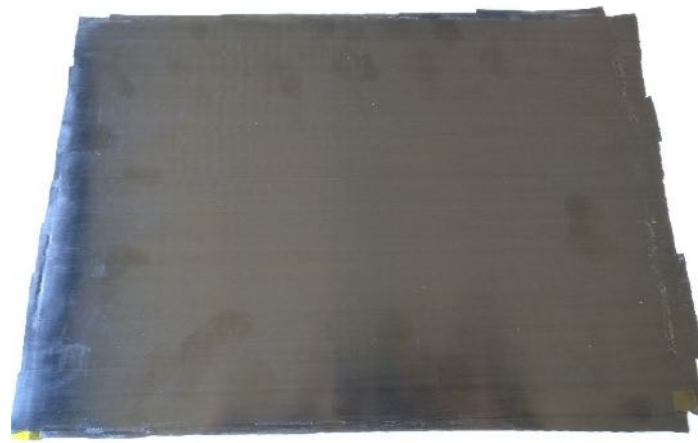

Consolidation trials: Huesker W8SVR



- Very good consolidation of layers
- Only little blurring of checkered pattern
- Higher process speeds possible, but currently limited by:
 - Inhomogeneous inductor temperature of machine width
 - Cooling module length
- Machine design can easily be adopted for a tailored consolidation line

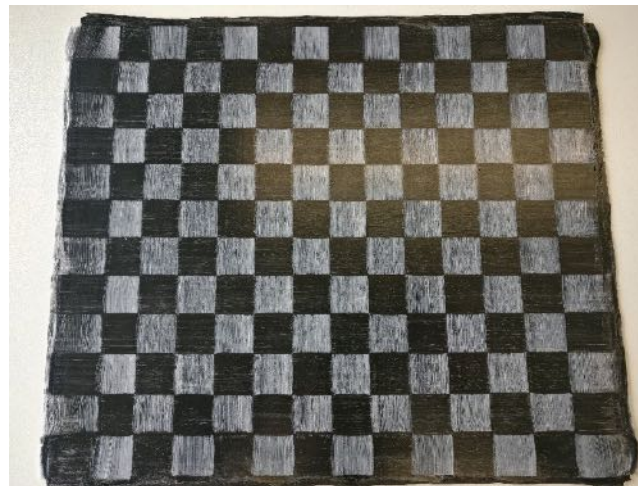

Summary of Conbility's Machine Portfolio

**Energy-efficient
Double Belt Press**

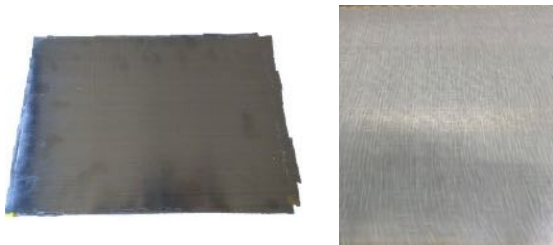

**2D Tape Placement Machine
with integrated Laser System**



**3D Tape Placement and
Winding Systems**



Exemplary Parts: Local Reinforcements and Tailored Blanks

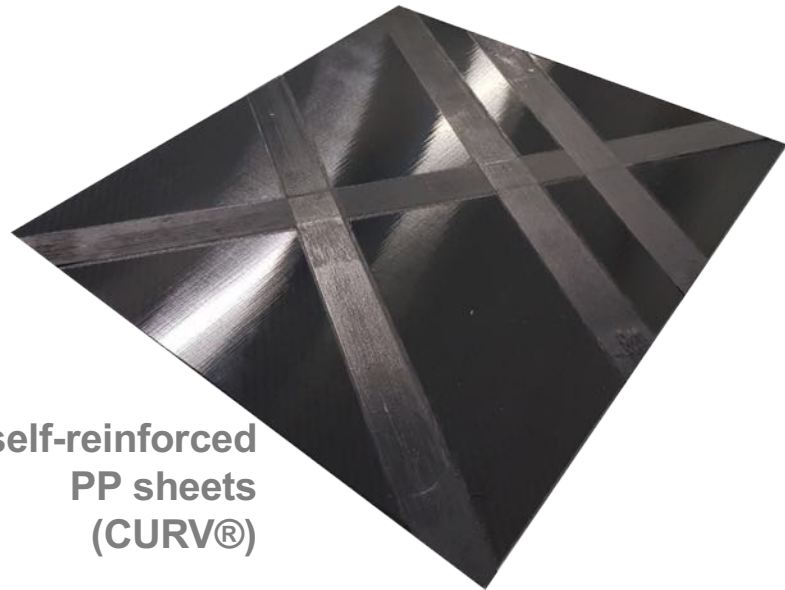

self-reinforced
PP sheets
(CURV[®])

Pre-consolidated Flax-
PP NFC-Sheets

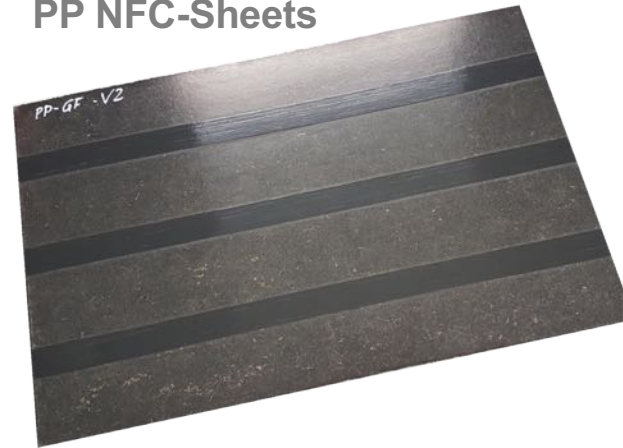

Tailored blanks with / without cut outs



thin injection molded parts

DeliComp[®] Prepregs

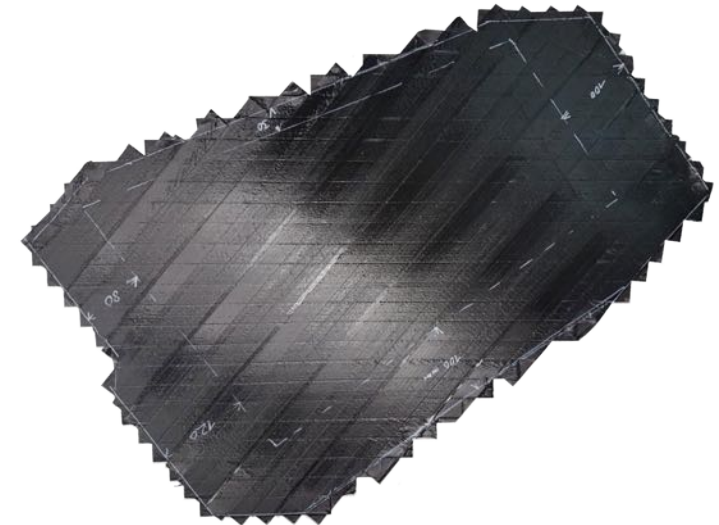

Your Contact



Dr.-Ing. Kai Fischer

Founder & Managing Partner

Phone: +49 176 72823544

E-mail: kai.fischer@conbility.com



Dr.-Ing. Michael Emonts

Founder & Managing Partner

Phone: +49 172 7207681

E-mail: michael.emonts@conbility.com

www.conbility.com